



SISTEMI DI FERRAMENTA
PER PORTE E FINESTRE

TENAX

Bocchetta di protezione per cilindri



ESTETICA

La particolare geometria a piani obliqui lo rende inafferrabile

RESISTENZA

Il pezzo viene ottenuto lavorando un pieno in acciaio inox speciale temprato AISI 420 con durezza di oltre 55 HRC

DURATA

Superficie antigraffio e resistenza alla corrosione in nebbia salina di oltre 1000 ore (SS DIN 50021; 5% sale; 35°C)

VERSIONI

Tonda e Ovale; Cromato Satinato e PVD dorato; 5 versioni con spessori (da 10 a 18 mm)



Scelta dello spessore "X" del TENAX in base alla sporgenza "S" del cilindro SCUDO

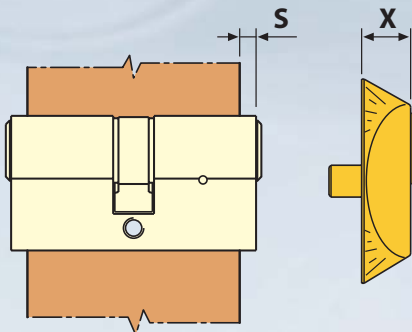

GR	X mm	S mm
1	10	0÷4
2	12	0÷6
3	14	2÷8
4	16	4÷10
5	18	6÷12



Tenax tondo
(interasse fori 38 mm)



Tenax ovale
(interasse fori 20 mm)

NB. Il Tenax é compatibile con cilindri SCUDO AGB
Per altre informazioni contattare l'Alban Giacomo Spa

SICUREZZA

Per una maggiore sicurezza utilizzare
TENAX in abbinamento con:

SCUDO DEK

Cilindro di sicurezza con codice PIN



SICURTOP POSEIDON

Serratura Multipunto di sicurezza



GAMMA TENAX

VERSIONI	TENAX	BOCCHETTA	ROSETTA con OR	ROSETTA PIANA	VITI	FINITURA
<p>TONDO C94850XX35</p>	V	V	V		V	PVD
<p>TONDO C94600XX35</p>	V			V	V	PVD
<p>TONDO C94850XX32</p>	V	V	V		V	OCS
<p>TONDO C94600XX32</p>	V			V	V	OCS
<p>OVALE C94700XX35</p>	V			V	V	PVD
<p>OVALE C94700XX32</p>	V			V	V	OCS

NB. Nei codici riportati in tabella, la variabile XX corrisponde al GR desiderato (es. 01-02-03-04-05)